

Specification Sheet

VS501 SWEEPER

Series VS501

Sheet 1 of 1

Issue Number: 02-13

Subject Technical Information and Data

Date: 16.04.2013

Reference: ECM 710396

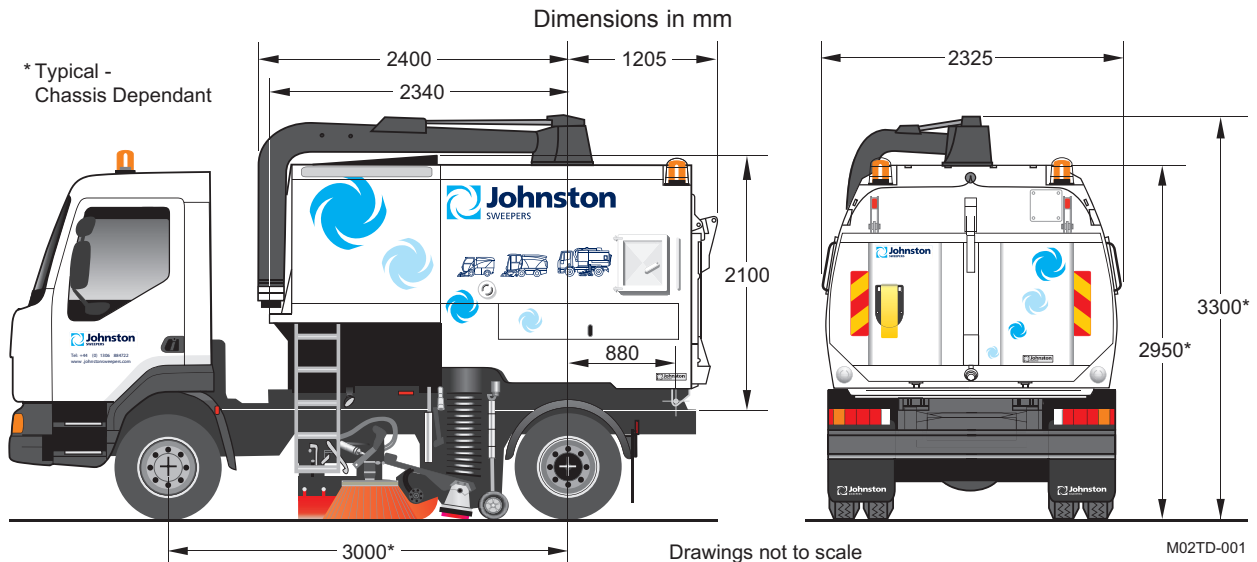

Data and Performance Information

Capacities	
Hopper voided volume	5.1 m ³ nominal
Payload voided volume	4.6 m ³ nominal
Payload capacity	3.0-4.0 Tonnes (chassis dependent)
Fuel tank	190 litres
Water tank	1360 litres

Hydraulic gearbox Data	
Propulsion pump	55 cc/rev. variable output
Pump pressure	420 bar forward (350 bar reverse)
Propulsion motor	160 cc/rev variable
Work input speed	Up to 1700 rpm*
Input ratio	49:34
Output ratio	64:19
Hydraulic suction filtration	125 µm
Boost canister filtration	10-20 µm absolute
Oil cooler fan speed	2150 rpm @ 1600 rpm engine

Fan Pump/Motor Data	
Pump	57 cc/rev variable output
Input speed	Up to 2300 rpm @ 1600 rpm engine
Pressure	145-175 bar
Motor	40 cc/rev (bent axis)

Sweeping Equipment	
Channel brush (CB)	Ø 500 mm
Wide sweep brush (WSB)	Ø 340 mm
CB life expectancy	80 accumulated working hours (nom)
WSB life expectancy	150 accumulated working hours (nom)
Nozzle trunking diameter	Ø 250 mm
Nozzle width	750 mm

General Data	
Chassis requirement	9.5 - 12 Tonnes
Wheelbase	3000 mm nominal
Discharge height	950 mm (nom) chassis dependent
Discharge angle	53° nominal
Door opening angle	125° nominal
Filter mesh area	1.05 m ²
Dust spray pump output	Up to 35 l/min
Dust spray water pressure	3-5 bar
Hydraulic suction filtration	125 micron
Hydraulic return filtration	25 micron
Hydraulic pump displacement	14 cc/rev. max output 32 litres
Hydrostatic speeds	0-40 kph (chassis dependent)

Johnston Sweepers Limited, Curtis Road, Dorking, Surrey RH4 1XF, UK
 Tel: +44 (0) 1306 884722 Fax: +44 (0) 1306 884151
 www.johnstonsweepers.com E-mail: enquiries@johnstonsweepers.com



Technical Specification

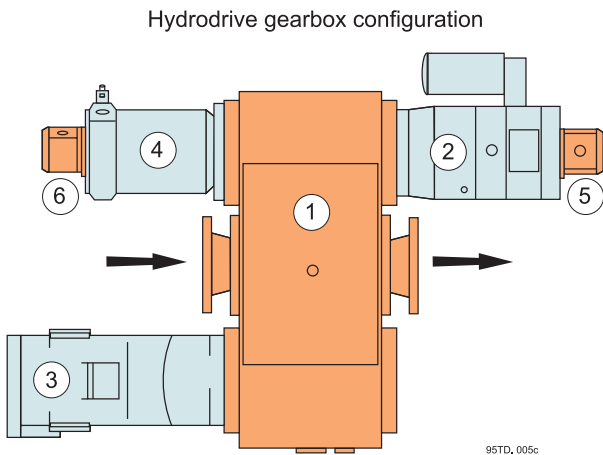
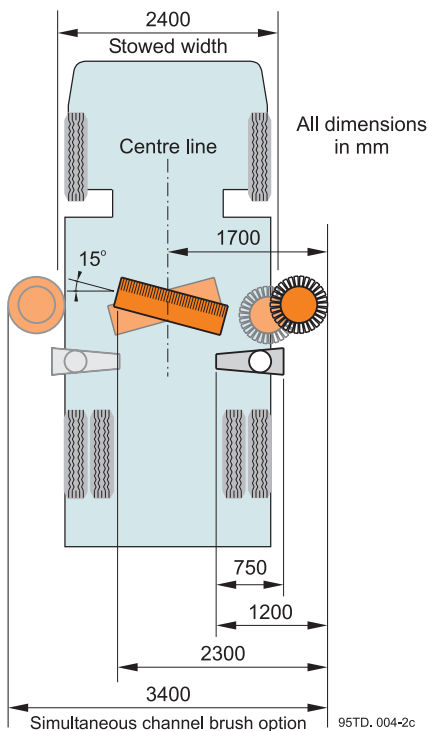

Key

- 1 - Hydrodrive gearbox.
- 2 - Vehicle propulsion pump.
- 3 - Vehicle propulsion motor
- 4 - Exhauster fan pump.
- 5 - Sweeping function pump (SF).
- 6 - Additional/optional equipment pump (AOP).

Base specification

Performance data

Exhauster fan:

Heavy duty, dynamically balanced impeller with multivane corrosion resistant blades. Operational speed variable between 2400 rpm - 3500rpm to suit operation. Driven from Johnston gearbox and pump unit combination.

Channel brush:

Quick release brush system with variable speed up to 200 rpm (cab controlled).

Nozzle:

Cast aluminium nozzle with 250mm diameter inlet and tool free adjustment.

Wide sweep brush:

Quick release brush system with a nominal 160rpm rotation speed.

Dust suppression system:

Dust suppression sprays located at suction nozzle(s), channel brush(es) and across front of vehicle.

Pressadrain water purging system.

Electrical system:

24 volt.

All external loom connections are full automotive IP67 rated.

Controls:

Centre cab mounted master control panel with Johnston Video Monitor (JVM) providing information on a wide range of sweeper functions plus data capture download. Up to four optional cameras can also be viewed on the JVM screen. Separate palm rest controller housing controls for the main sweeping functions is mounted on the door side.

In cab noise:

<75 dB(A) generally (dependent on chassis selection).

Exterior noise / Sound power level:

L_{WA} 110 dB(A) (dependent on chassis) measured in accordance with EC directive 2000/14/EC.

Body & Cowl

Body comprises of hopper & integral water tank. Fabricated from heavy duty stainless steel plate.

Cowling is lined with frequency matched soundproofing material.

Water tank incorporates anti-surge baffles

and filled via a type 'A' water hydrant fill. A twin diaphragm pump runs continuously and is able to run dry. Water tight twin lock rear door latching system with de-watering function. Two body side access doors. Plug in hopper floor as transfer port for use as Streetwasher. Rear discharge chute, twin rear caged beacons, automatic multi position body propping mechanism and side storage lockers are standard features.

Optional equipment

- Camera monitoring system.
- Littasnatch.
- Microtrap dust suppression system.
- Powathrust/Powasave.
- Pneumatic mesh shakers.
- Powascrub - wide sweep brush ground pressure device.
- Supawash - high pressure washing system 32 l/min @ 100 bar. Handlance, hosereel, front and nozzle spraybars.
- 6" or 8" boom mounted Wanderhose with power assist option.

A comprehensive range of additional options is available. Please ask for details.

Johnston Sweepers Limited, Curtis Road, Dorking, Surrey RH4 1XF, UK
 Tel: +44 (0) 1306 884722 Fax: +44 (0) 1306 884151
 www.johnstonsweepers.com E-mail: enquiries@johnstonsweepers.com

